

**DESCRIPTIF**

Menuiseries en PVC  
Gammiste : REHAU  
Gamme : S729 TITANIUM  
Avis technique : 4875A-242-69

**COLORIS**

Blanc teinté dans la masse

**VITRAGE**

Vitrage 28 mm 4/20/4  
isolation thermique renforcée (ITR)  
remplissage gaz Argon  
intercalaire Warm-edge

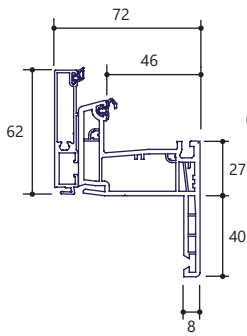
**PERFORMANCES**

Etanchéité à l'air : A4  
Etanchéité à l'eau : E7A  
Résistance au vent : VA2

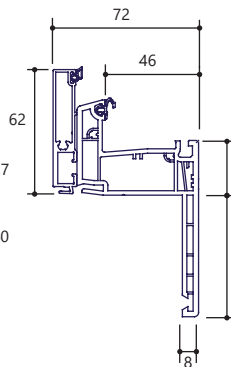
UW  
1 vantail : 1.3  
2 vantaux : 1.4

**DORMANTS**

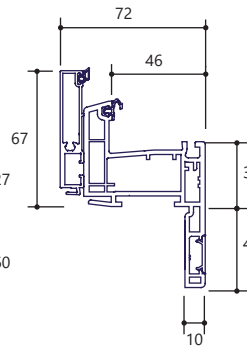
*Rénovation aile de 40 mm*



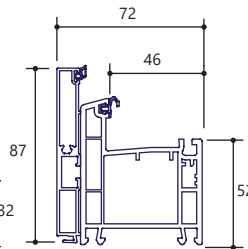
*Rénovation aile de 60 mm*



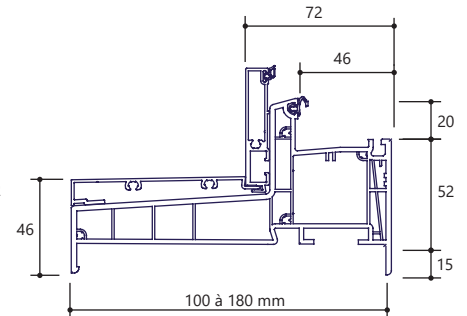
*Rénovation fixation façade*



*Neuf / Applique sans isolation*

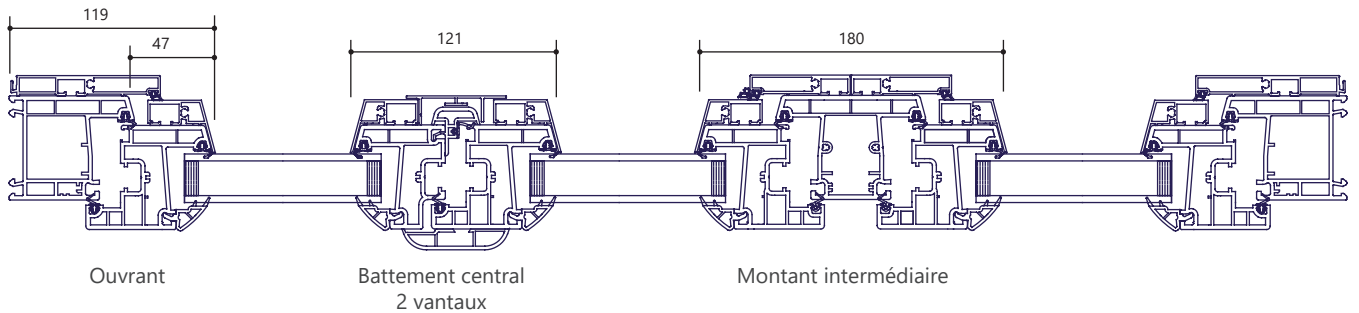


*Neuf / Applique avec isolation*

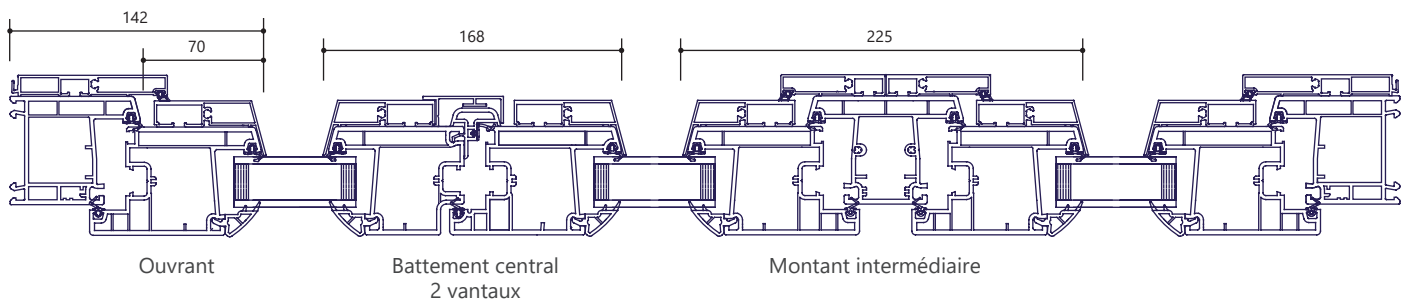


**OUVRANTS**

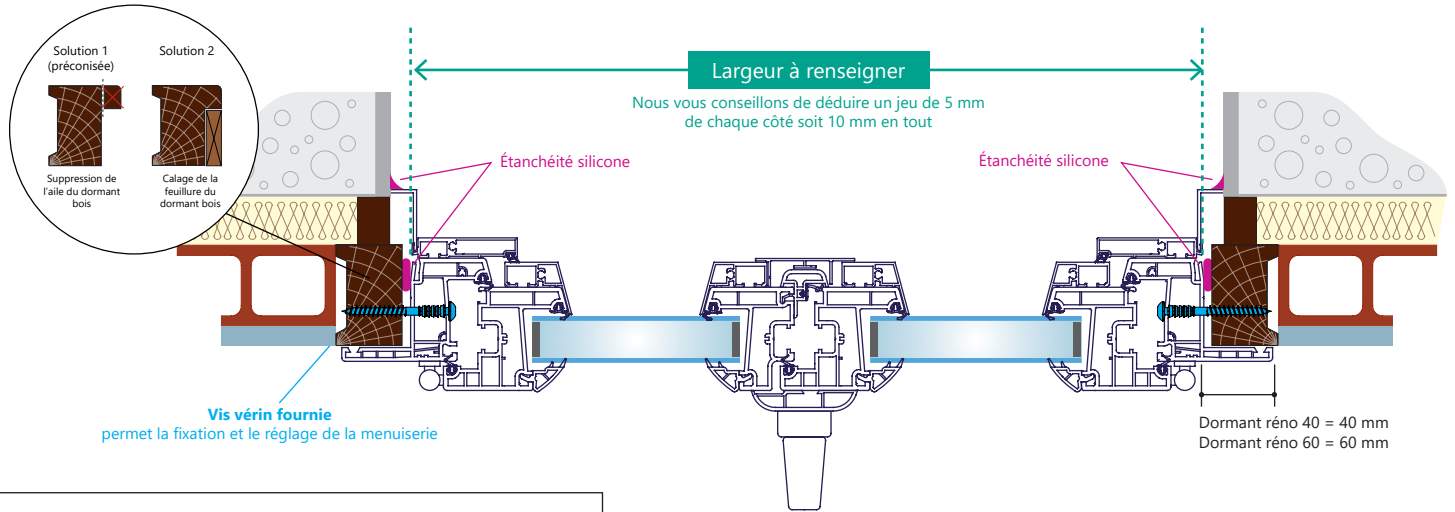
*Fenêtre et Porte-fenêtre crémonne (poignée intérieure)*



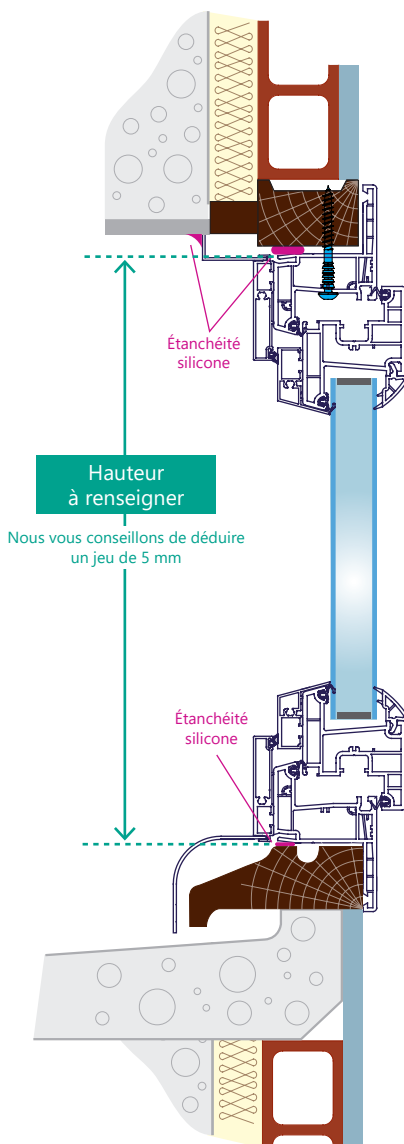
*Porte-fenêtre avec serrure à clé (poignée intérieure/extérieure)*



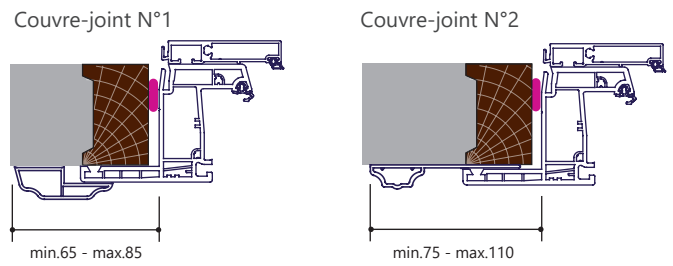
**Fig 1. Coupe horizontale**



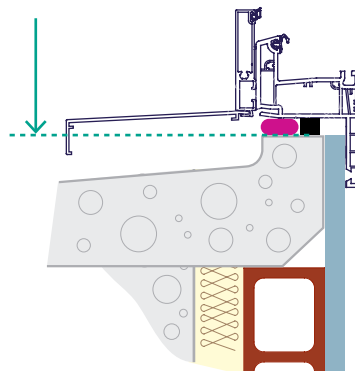
**Fig 2. Coupe verticale**



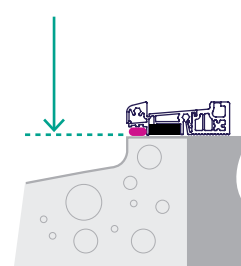
**Fig 3. Moulure(s) intérieure(s) rapportée(s) (option)**



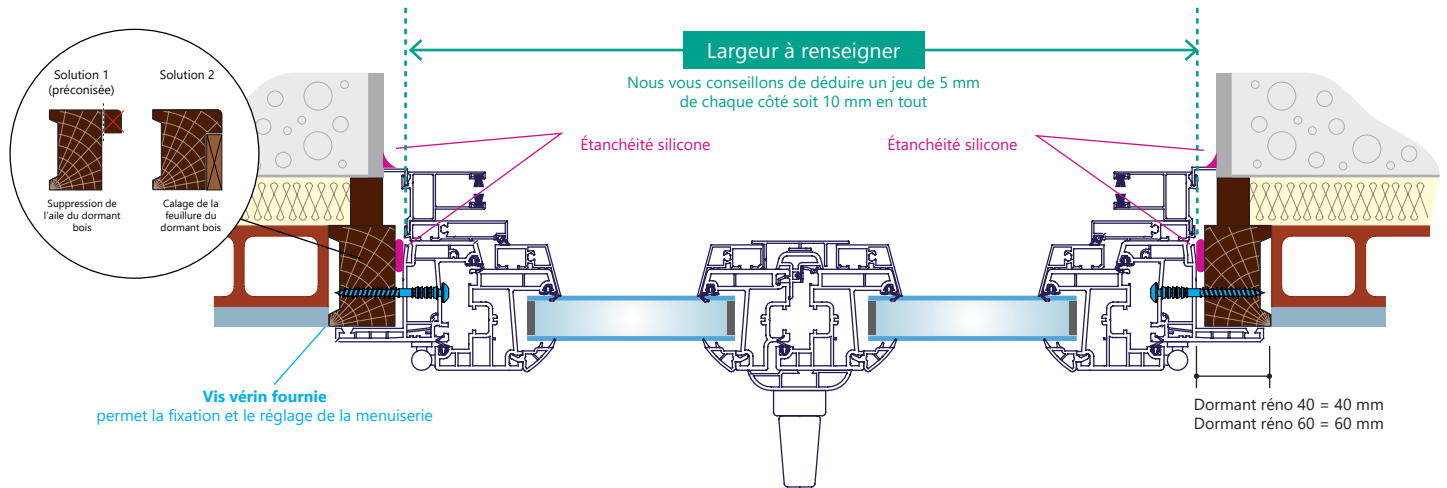
**Fig 4. Variante avec suppression de l'appui en bois**



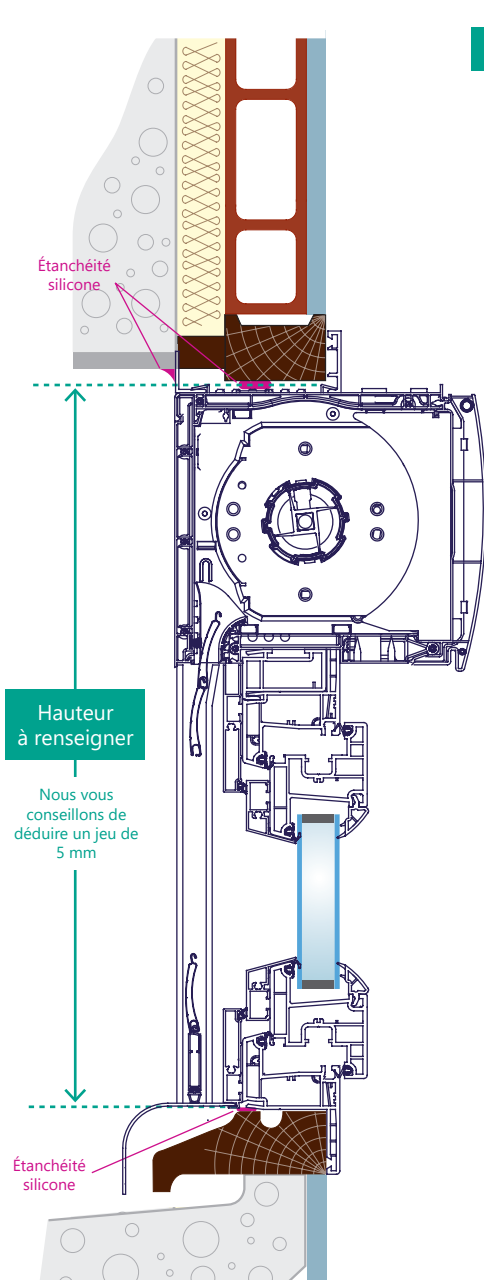
**Fig 5. Variante avec seuil en aluminium**



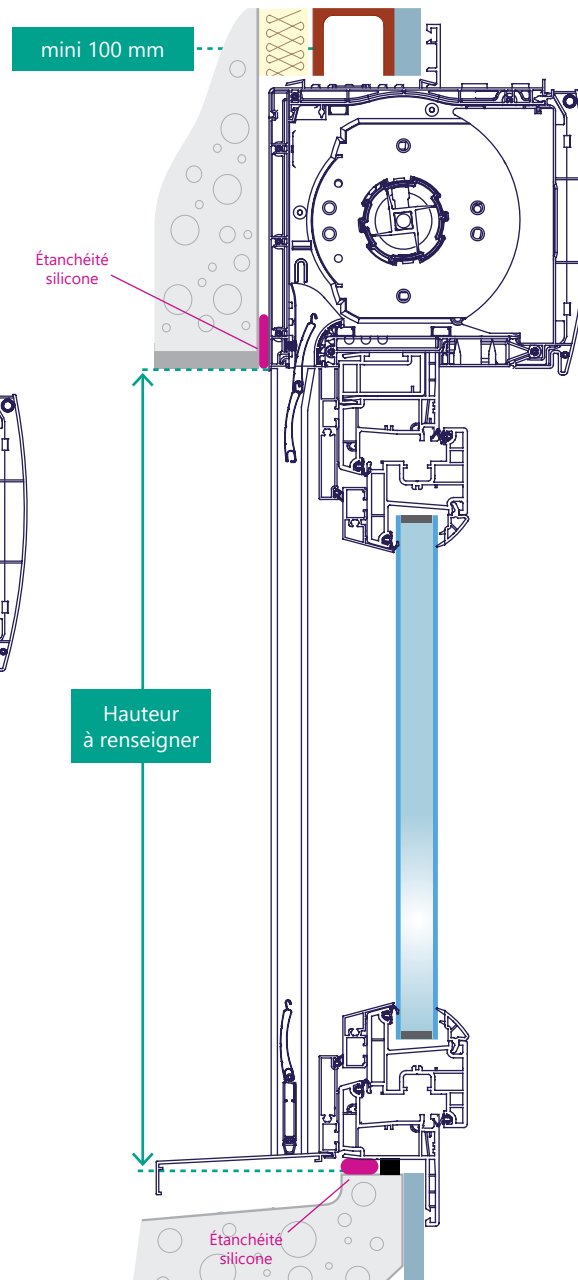
**Fig 6. Coupe horizontale**



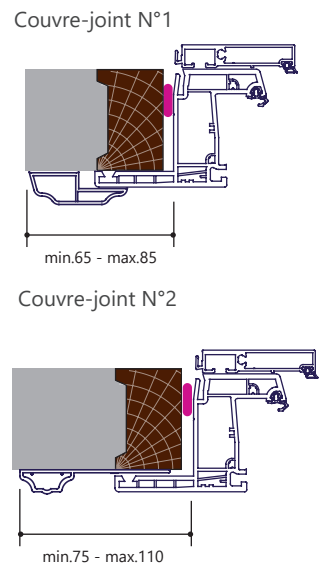
**Fig 7. Coupe verticale conservation** du dormant bois



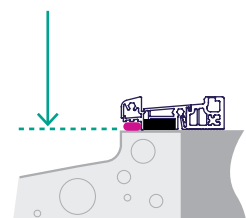
**Fig 8. Coupe verticale suppression** du dormant bois



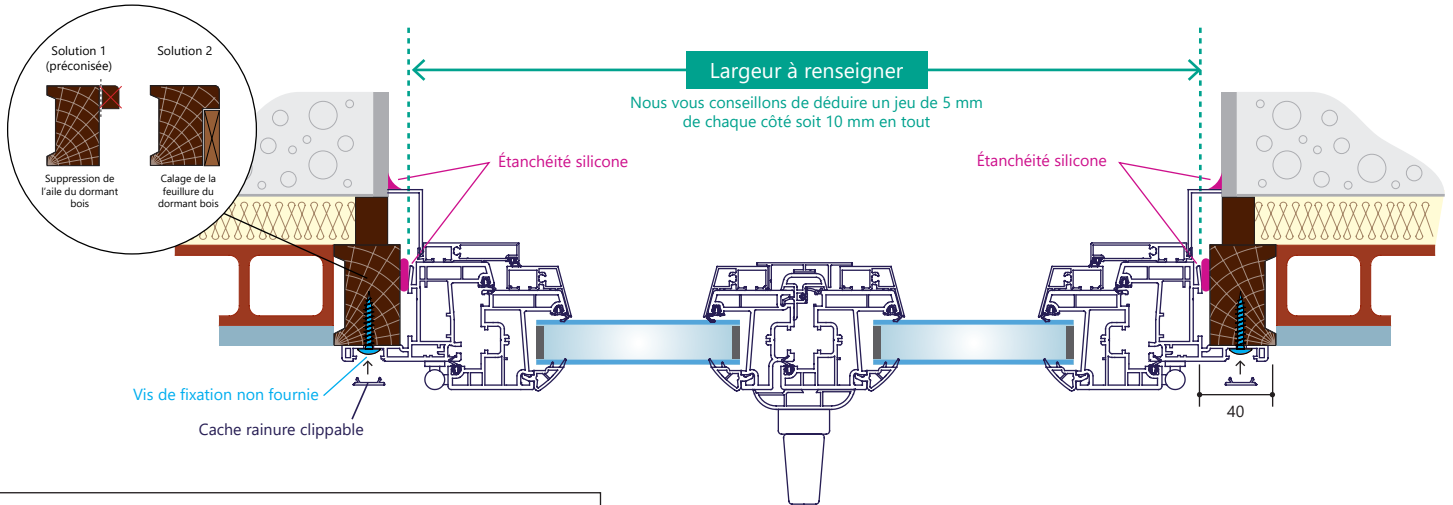
**Fig 9. Moulure(s) intérieure(s) rapportée(s) (option)**



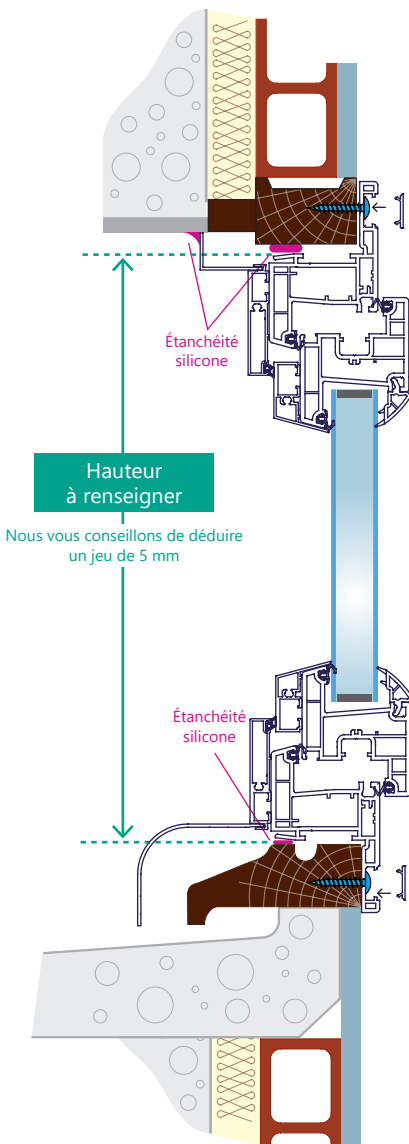
**Fig 10. Variante avec seuil en aluminium**



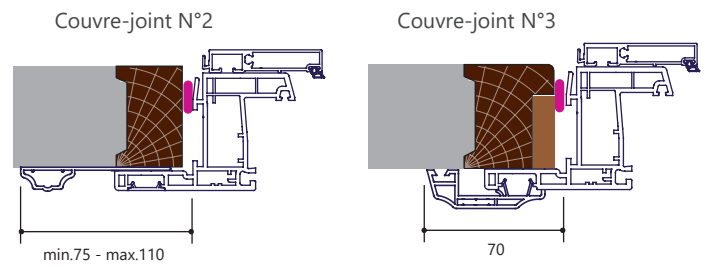
**Fig 11. Coupe horizontale**



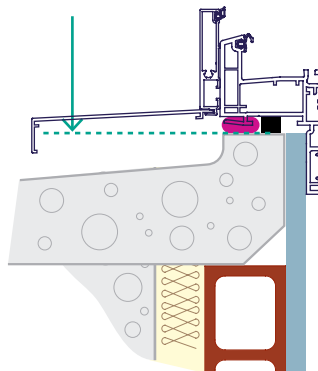
**Fig 12. Coupe verticale**



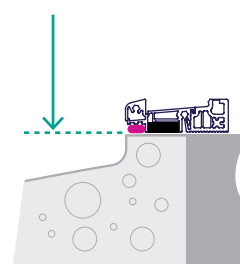
**Fig 13. Moulure(s) intérieure(s) rapportée(s) (option)**



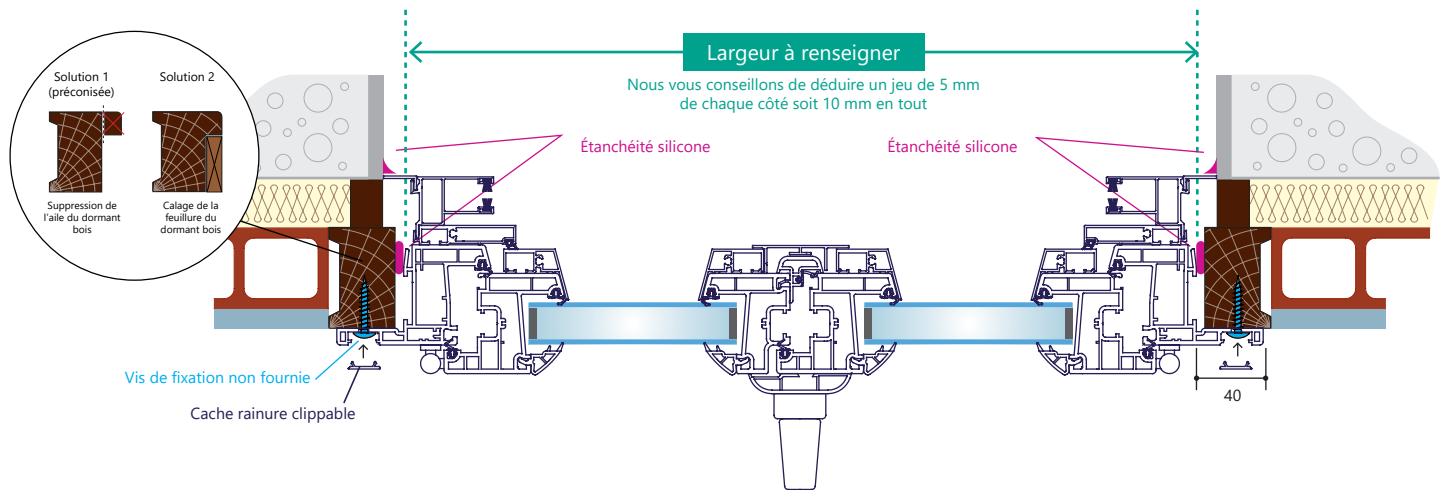
**Fig 14. Variante avec suppression de l'appui en bois**



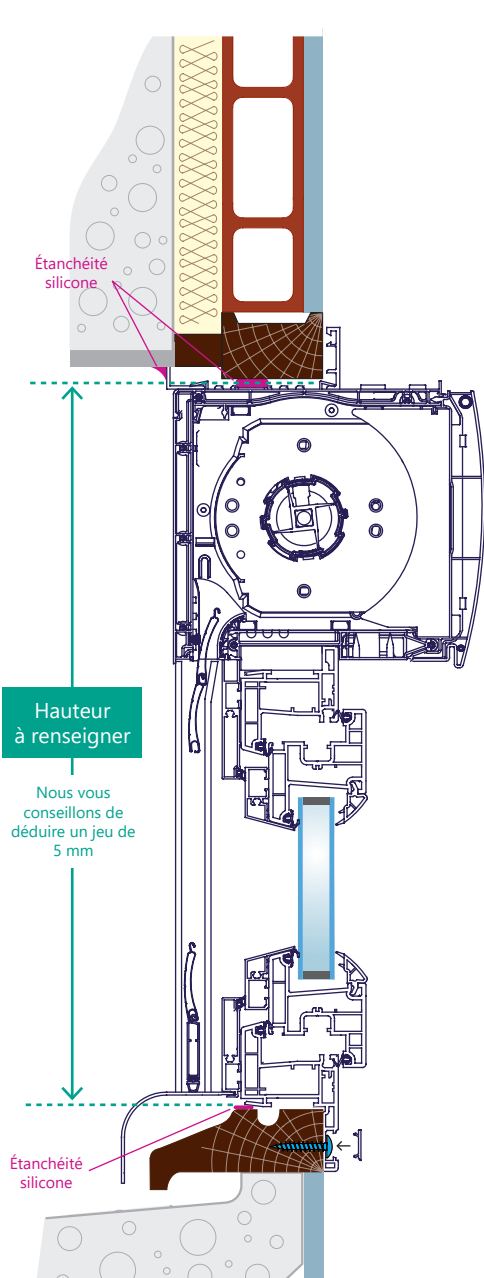
**Fig 15. Variante avec seuil en aluminium**



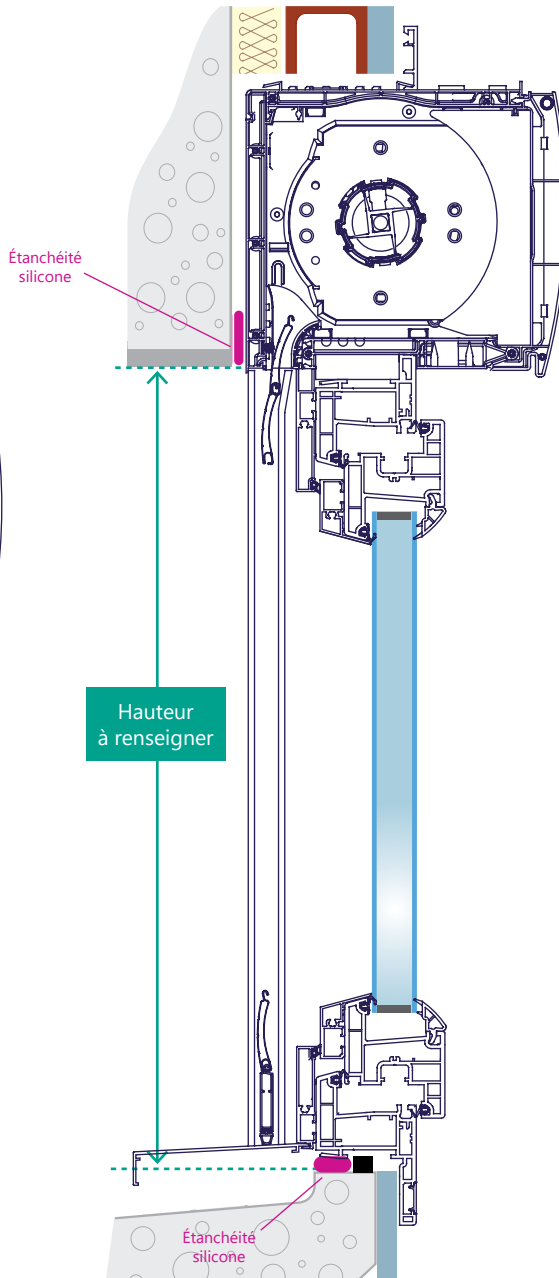
**Fig 16. Coupe horizontale**



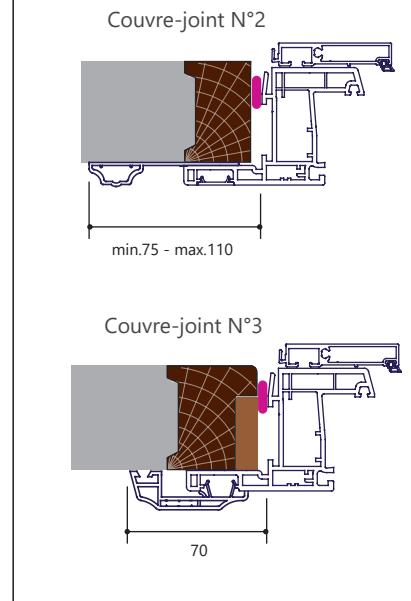
**Fig 17. Coupe verticale conservation** du dormant bois



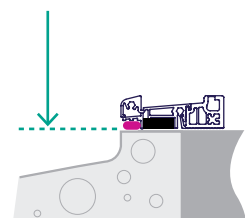
**Fig 18. Coupe verticale suppression** du dormant bois



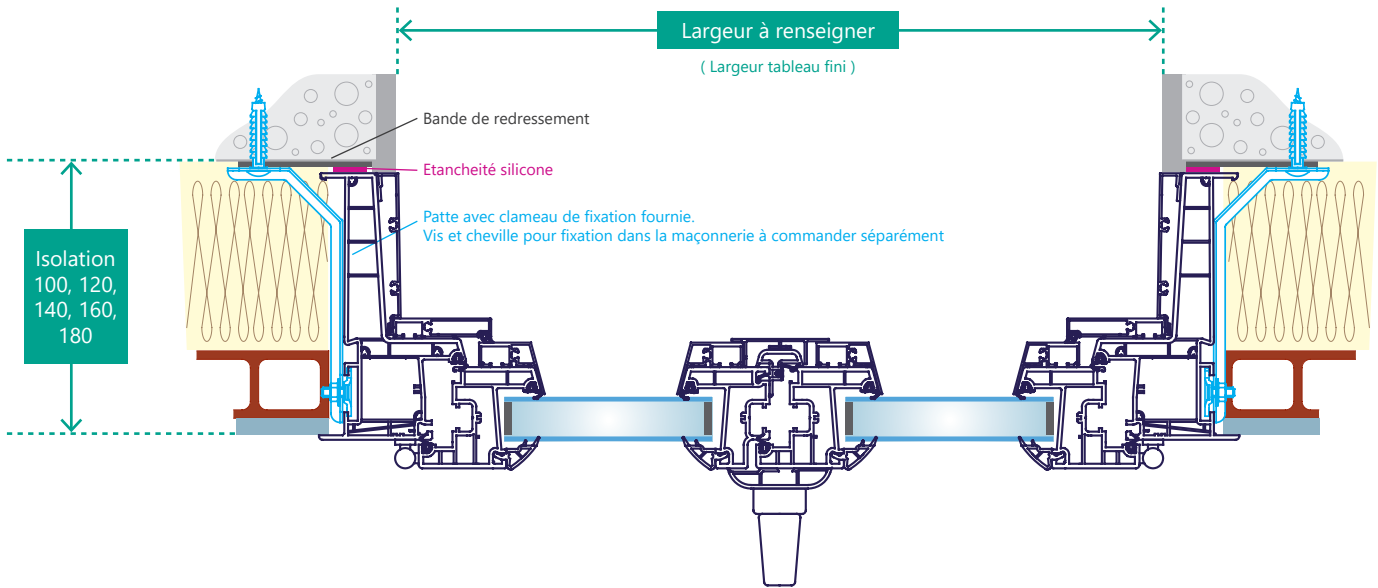
**Fig 19. Moulure(s) intérieure(s) rapportée(s) (option)**



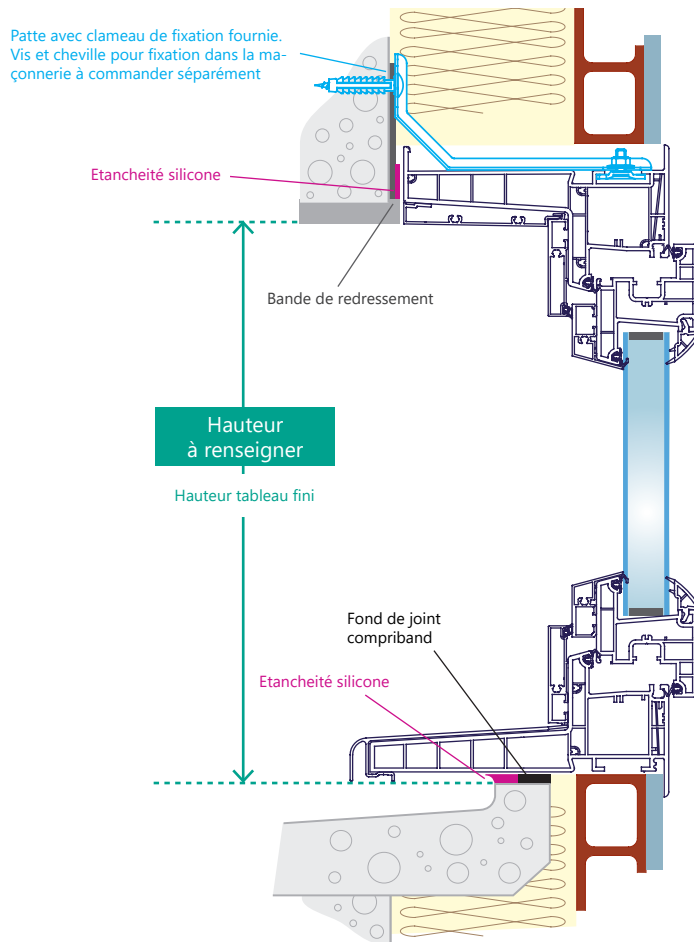
**Fig 20. Variante avec seuil en aluminium**



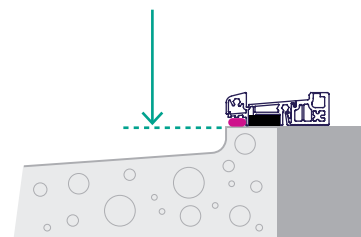
**Fig 21.** Coupe horizontale



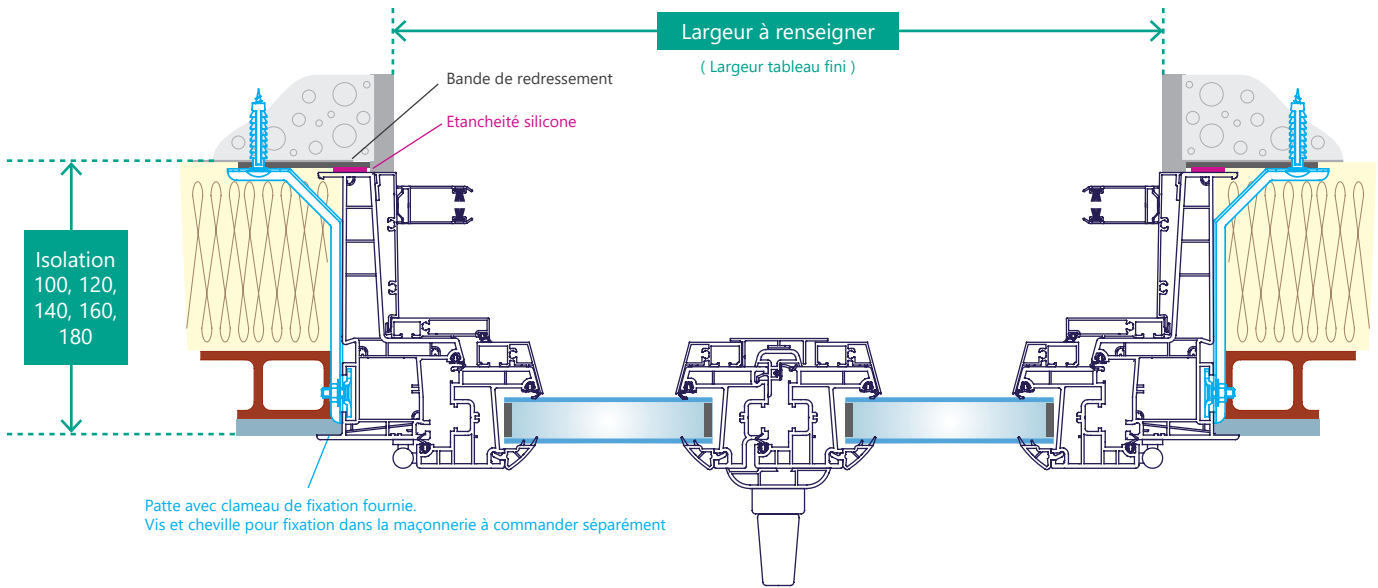
**Fig 22.** Coupe verticale



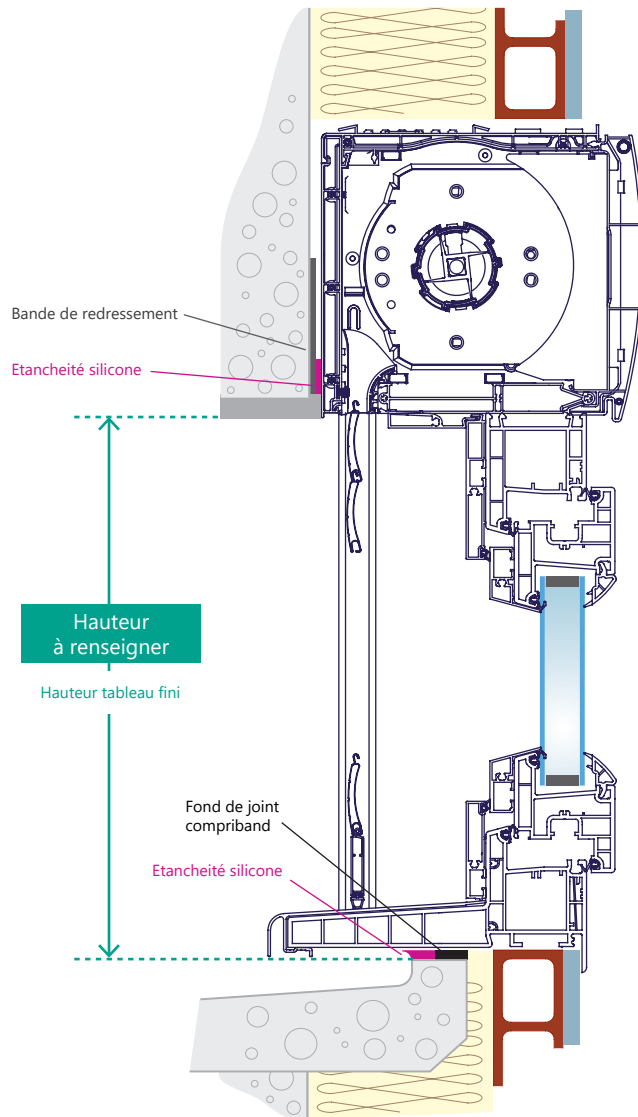
**Fig 23.** Variante avec seuil en aluminium



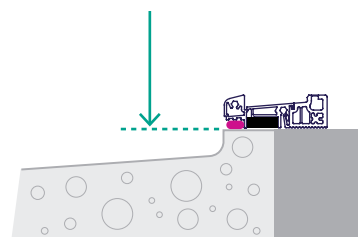
**Fig 24.** Coupe horizontale



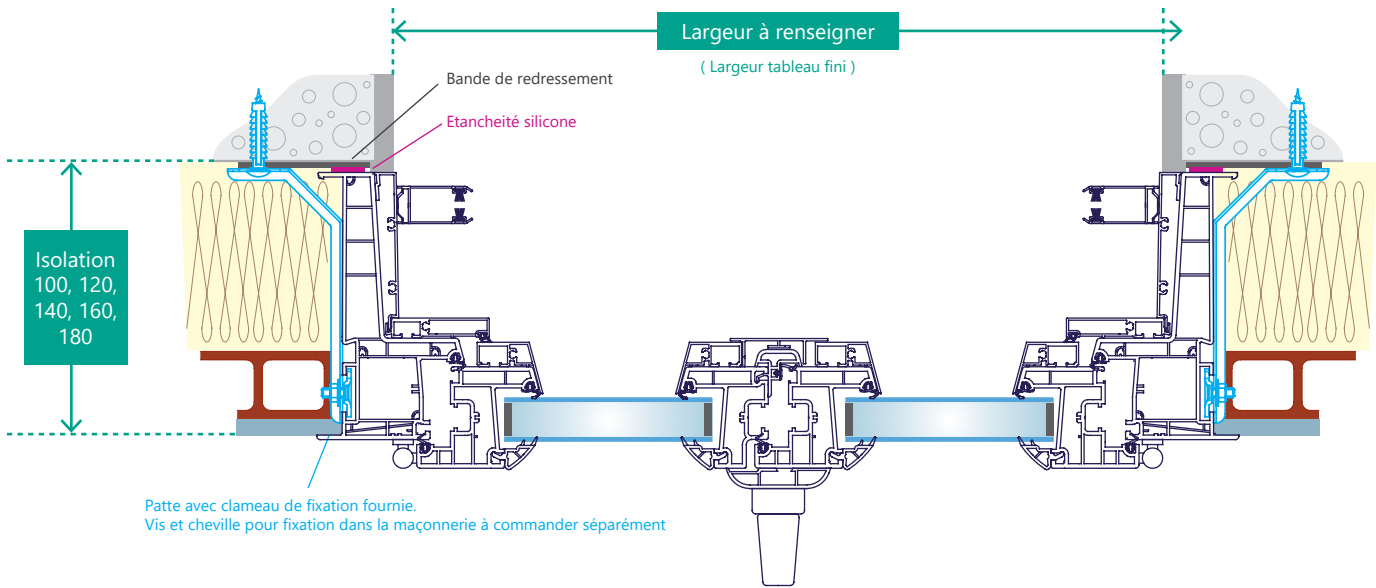
**Fig 25.** Coupe verticale



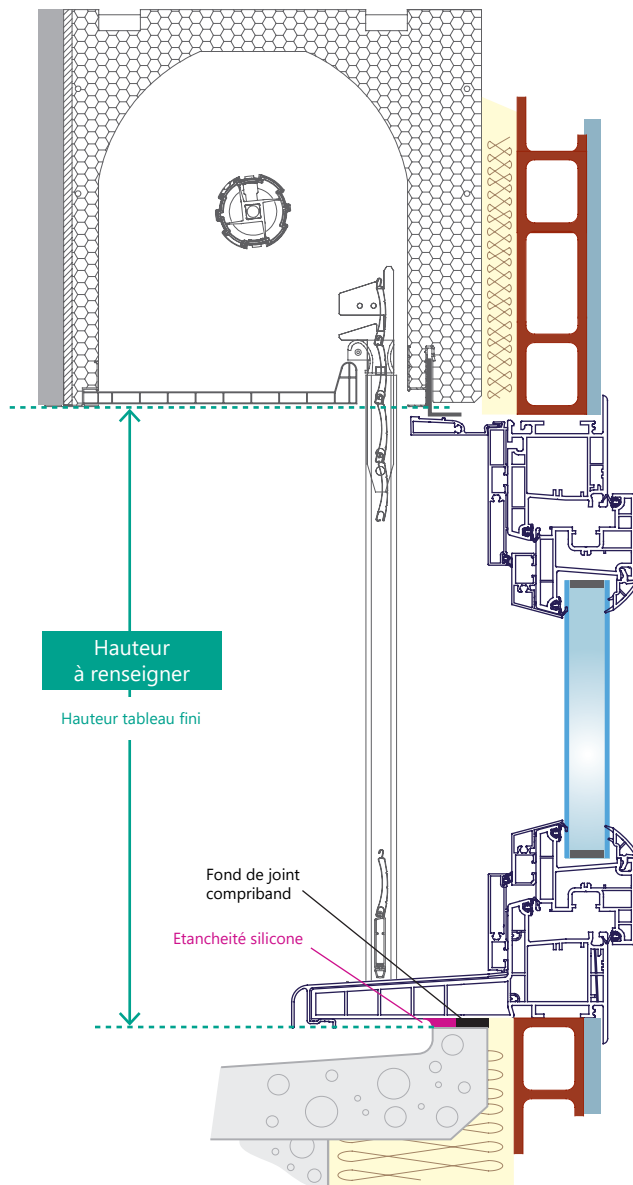
**Fig 26.** Variante avec seuil en aluminium



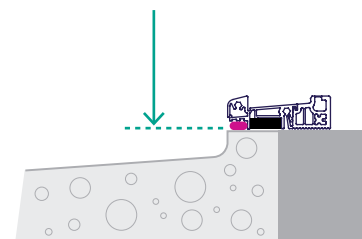
**Fig 27.** Coupe horizontale



**Fig 28.** Coupe verticale

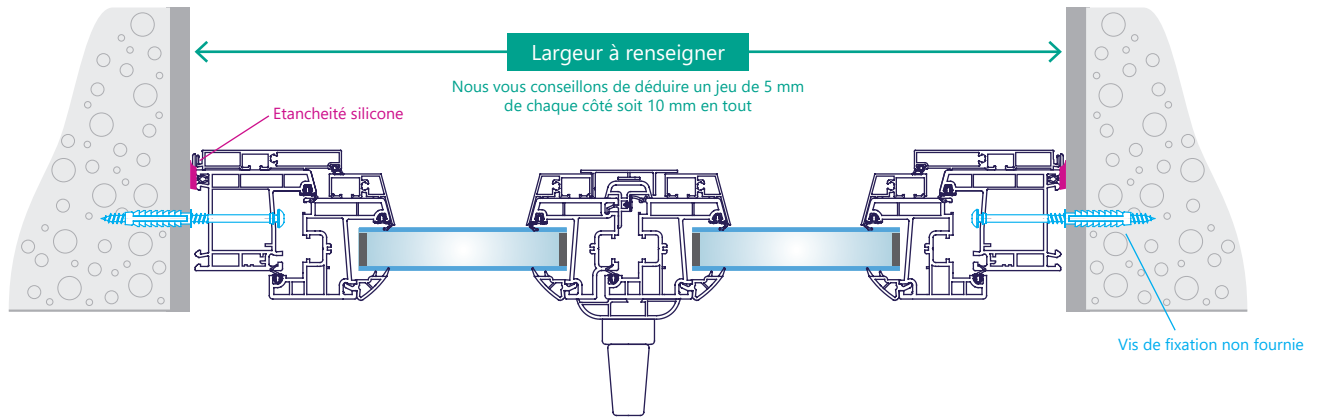


**Fig 29.** Variante avec seuil en aluminium

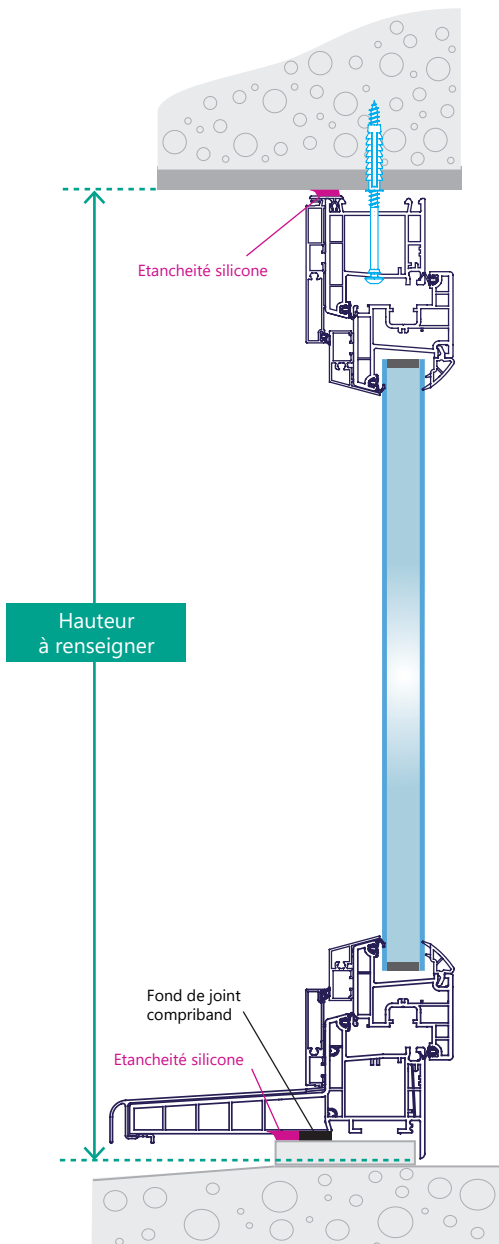




**Fig 30.** Coupe horizontale



**Fig 31.** Coupe verticale **sans volet roulant**



**Fig 32.** Coupe verticale **avec volet roulant**

